

TROQUEL DE CORTE TRIANGULAR

Velocidad: hasta 300 golpes por minuto
 Materiales: PP, PE, BOPP, PVC, etc.
 Espesores desde 0,01 mm – 0,05 mm

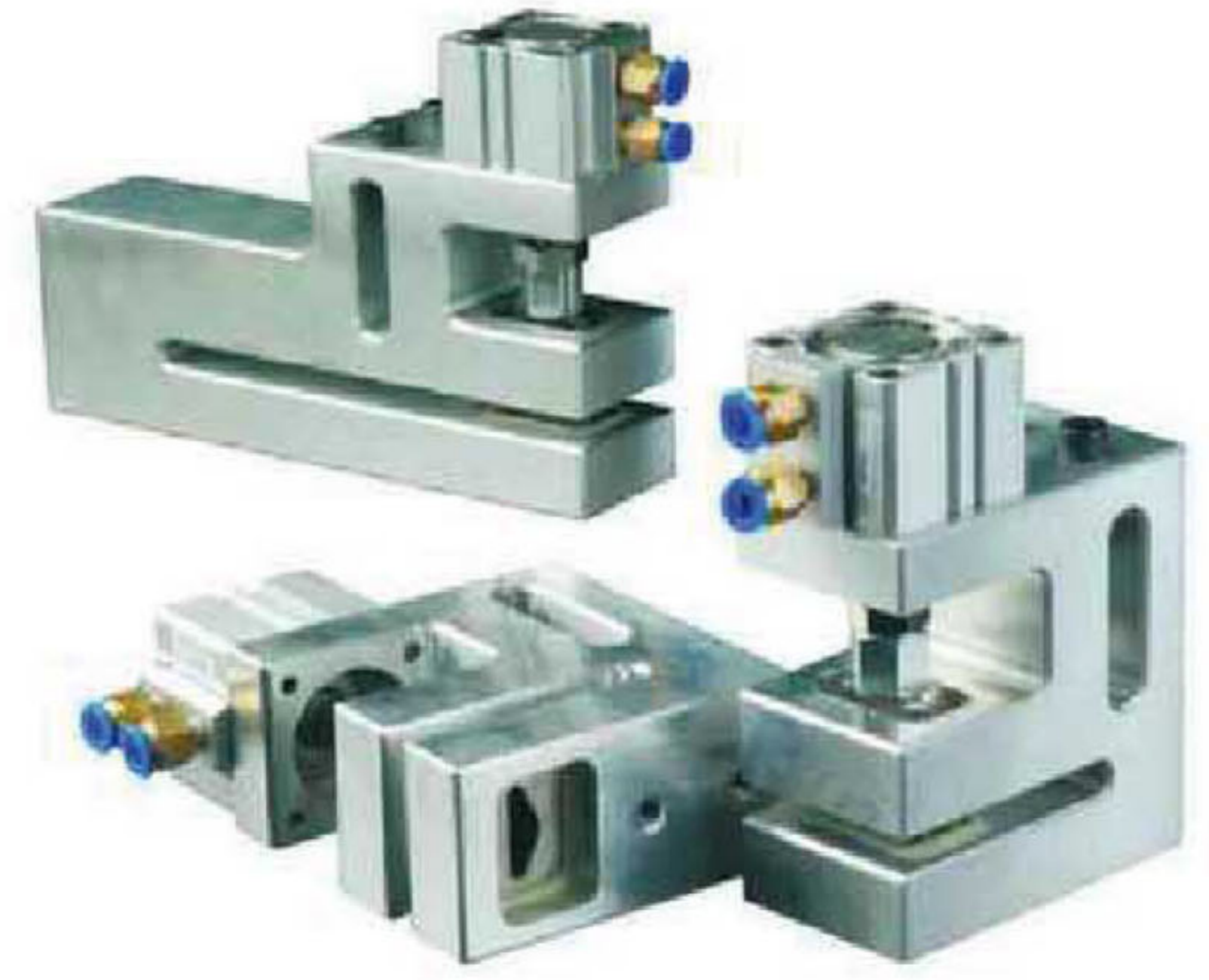

Referencia de Diseño de Troquelado

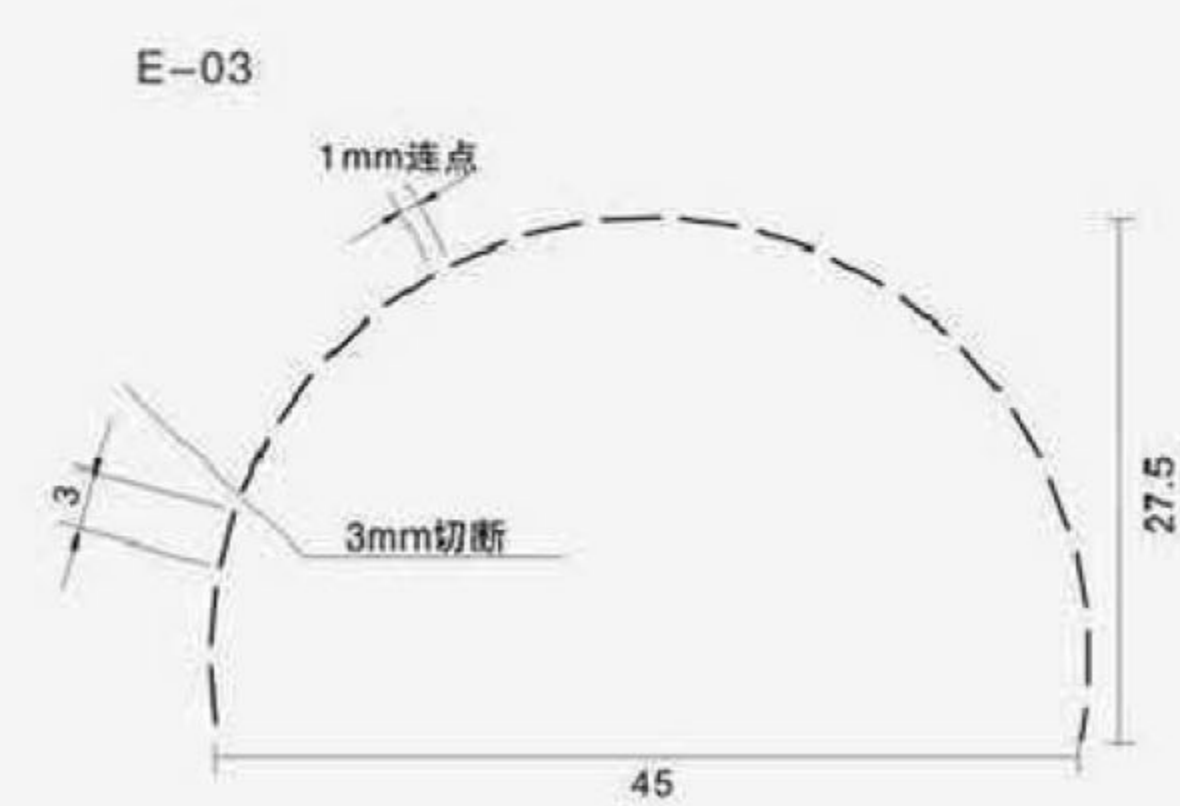
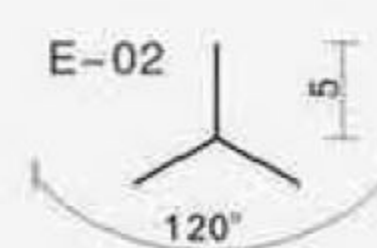
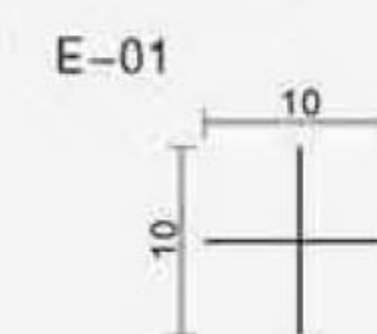
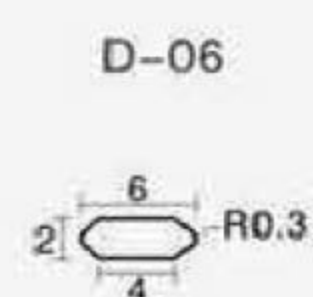
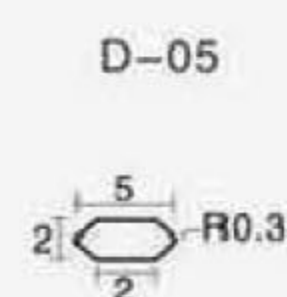
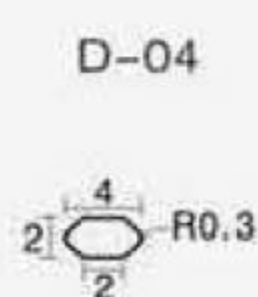
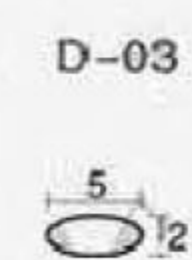
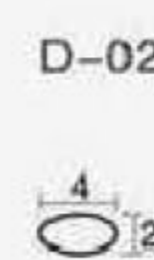
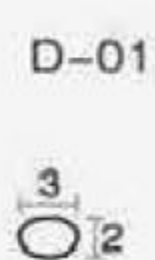
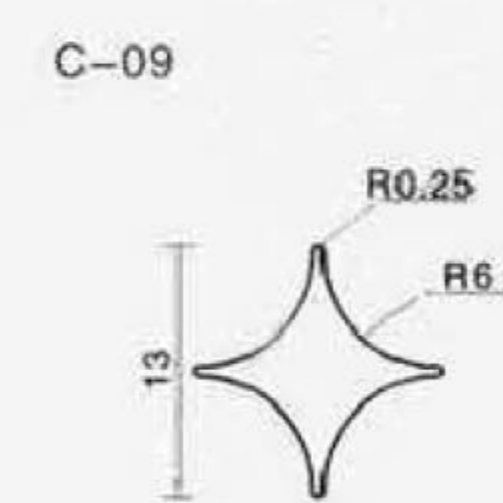
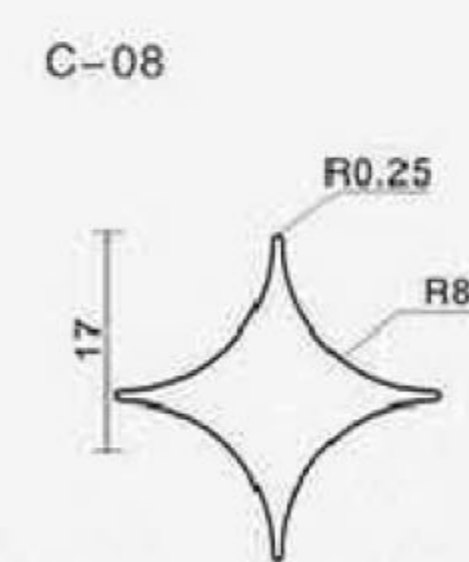
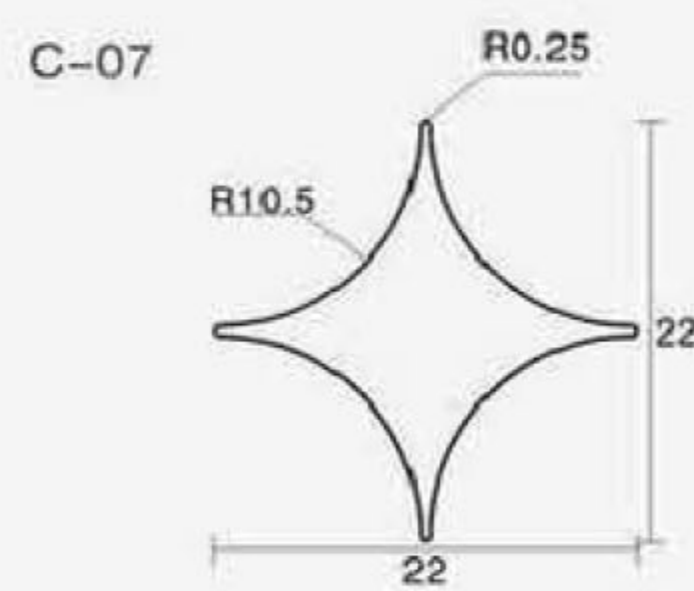
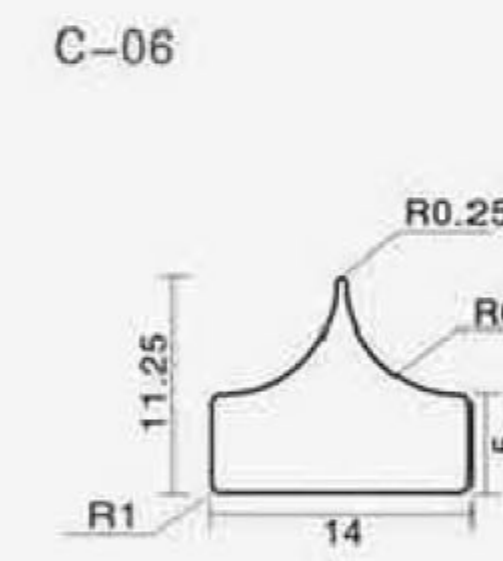
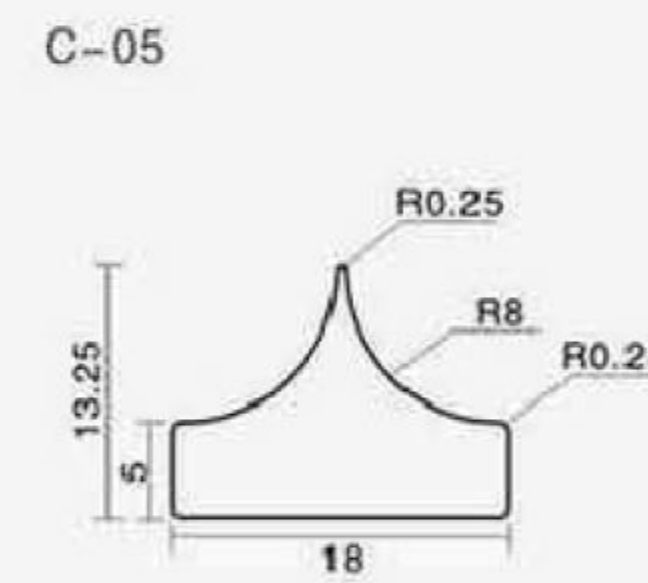
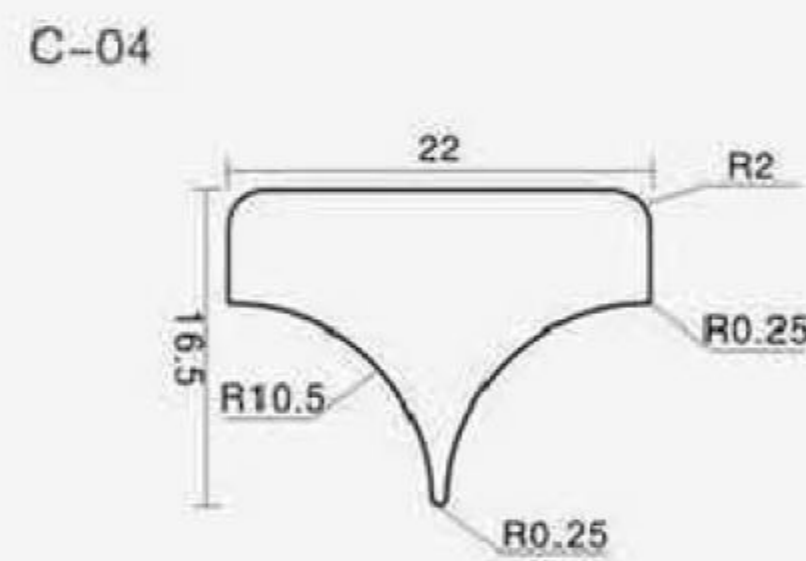
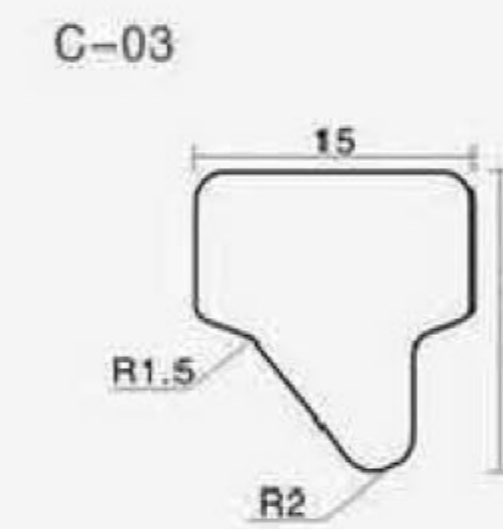
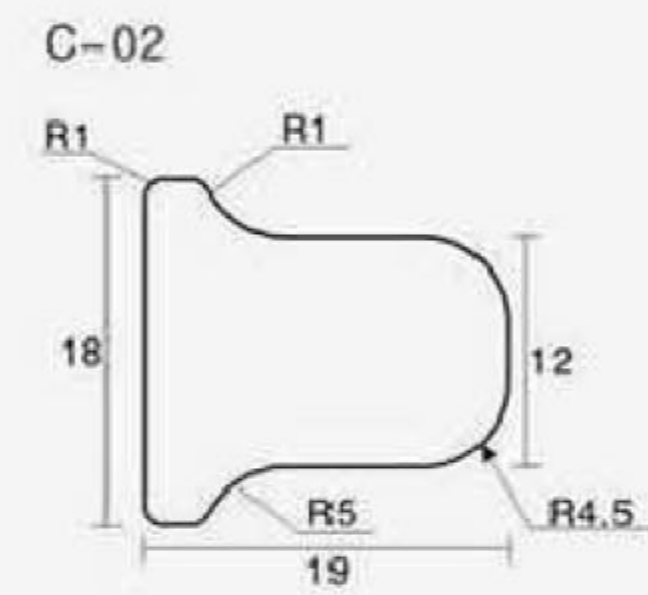
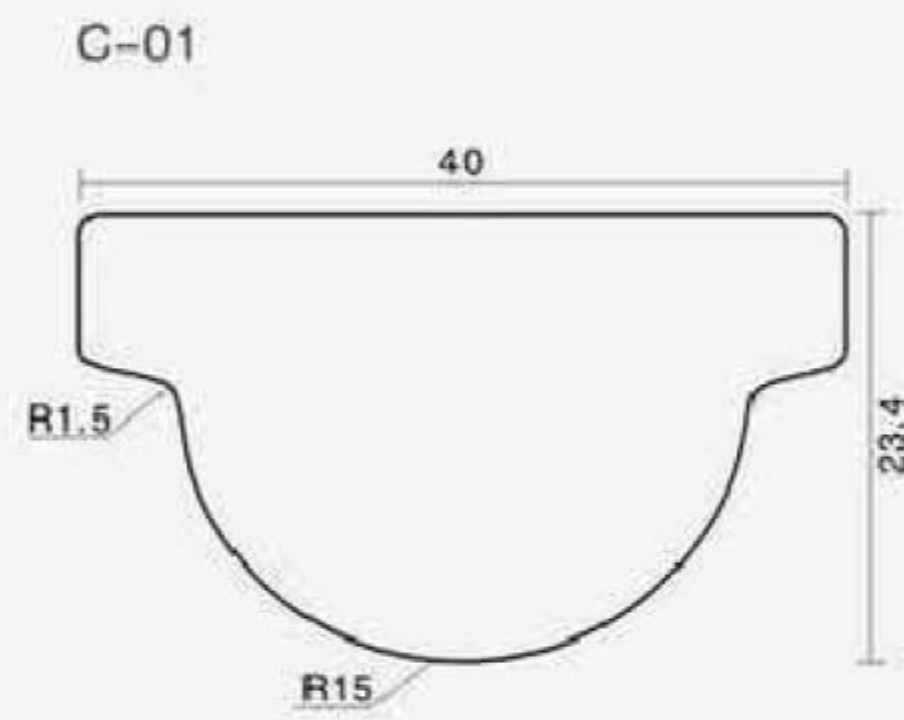



Referencia de Diseño de Troquelado

